



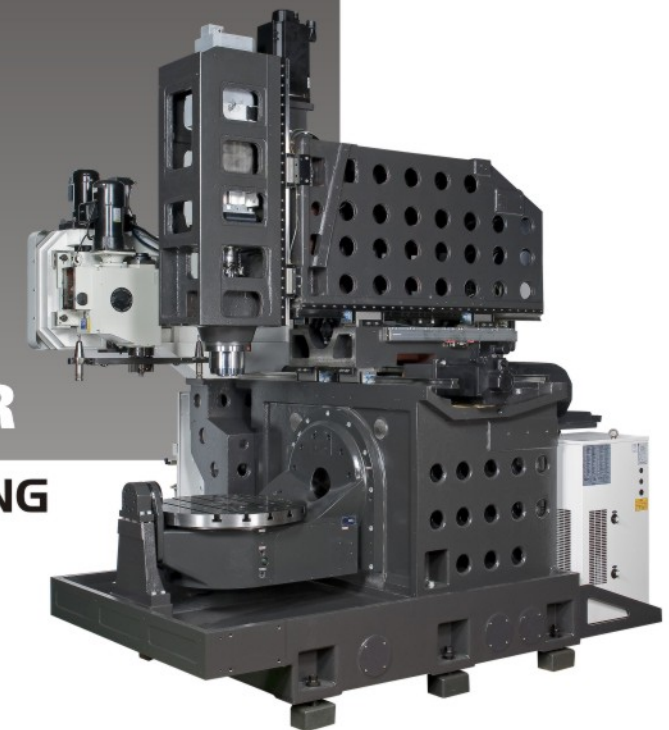
MATCHMAKER
CNC

MATCHMAKER CNC

Unit 5, Leatherhead Trade Park,
Station Road, Leatherhead, Surrey KT22 7AG
Tel:01372 844999 Fax:01342 844998

E-mail:sales@matchmakercnc.co.uk www.matchmakercnc.co.uk

MATCHMAKER
VERTICAL MACHINING
CENTRE (5 AXES)
ML-620



Simultaneous

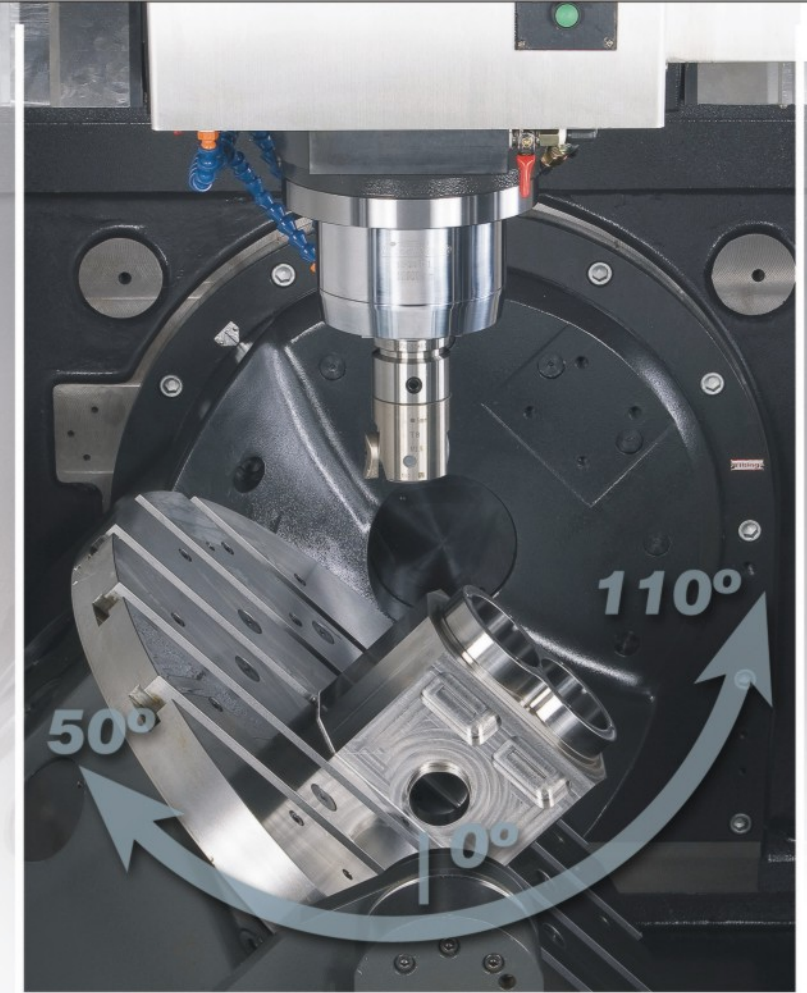


MATCHMAKER
CNC

MATCHMAKER 5-axis **Vertical** **Machining Centre**

High Speed Machining Helps You Stay Ahead

The **MATCHMAKER ML-620** is an advanced, multitasking 5-axis vertical machining centre designed for producing complicated parts at high speed. With a 5-axis configuration, complex machining can be accomplished in one setup. This dramatically reduces machining time, while helping you stay competitive.



Rotating / Tilting Axis (B, C-axis)

The high rigidity NC controlled rotating/tilting rotary table is equipped with linear encoders, assuring high accuracy in simultaneous machining of 5 axes and positioning at any angle. As a result, you get excellent accuracy when performing complicated parts machining.

Features of B, C-axis

- *B-axis tilting angle: -50° ~ +110°*
- *C-axis rotating angle: 360°*
- *B, C-axis are driven by independent motors*
- *Max. table load on B, C-axis: 300 kg*
- *B, C-axis speed: 25 rpm*
- *Clamping force: 4410 Nm on B-axis and 2450 Nm on C-axis*

State of the Art Structural Design

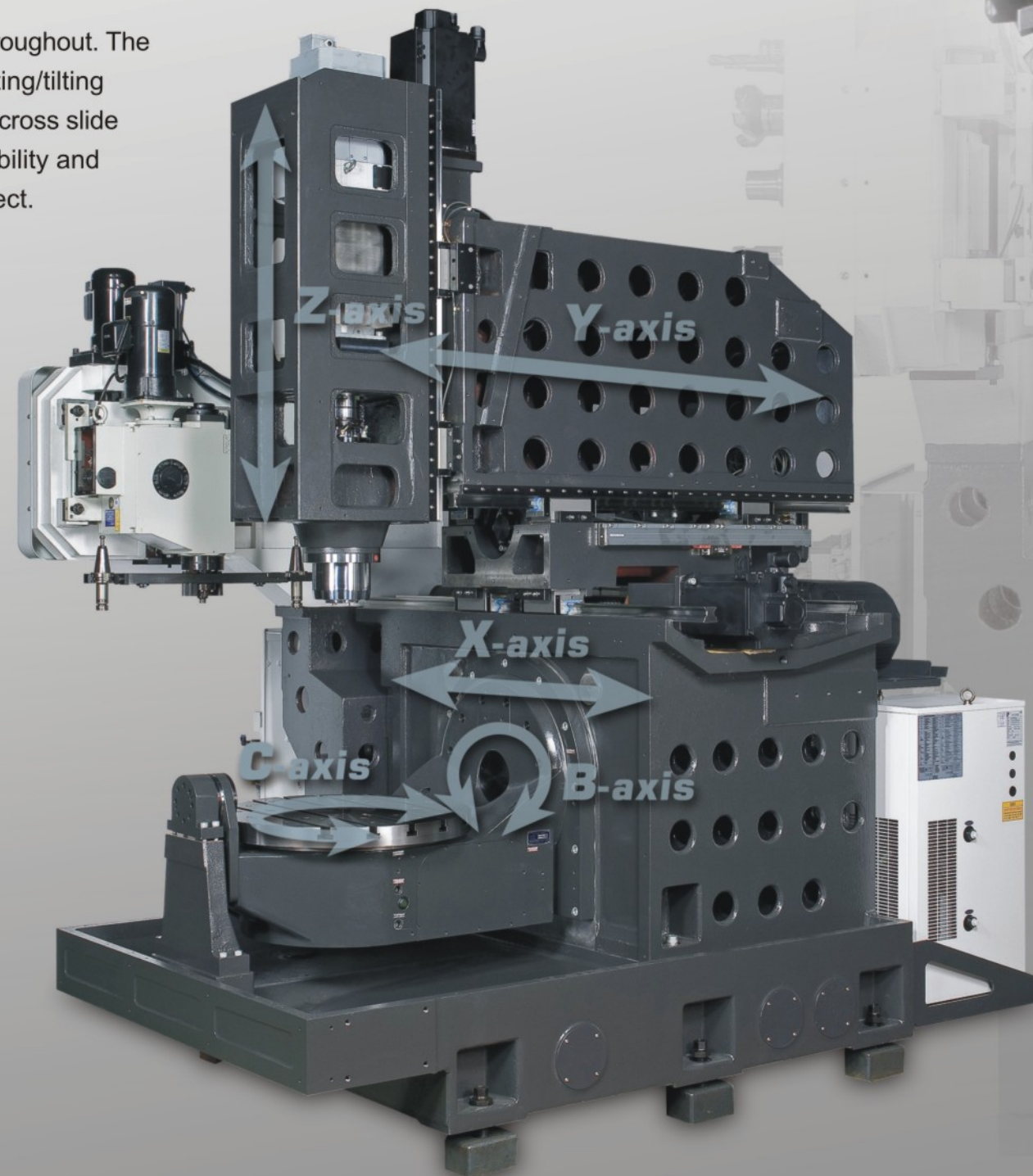
Maximized Rigidity and Stability with Advanced Structure

The **ML-620** is ruggedly constructed throughout. The rigid base provides solid support for the rotating/tilting rotary table (B, C-axis). This combined with a cross slide design on the X and Y-axis ensures high stability and the machining accuracy you've come to expect.



Heidenhain iTNC-530 Control

- 5 axes simultaneous control
- The advanced control will dramatically improve machining accuracy, efficiency and safety during machining.



32 Tool Chain Type Magazine

- The magazine permits tool loading and unloading during machining.
- The magazine accommodates an NBT 40 tool shank (standard); ISO 40 / CAT 40 tool shank is optional.

Precision and Capacity make ML-620 a Super Performer

- Handles complicated machining with ease
- Linear scales/enconders on 5 axes.
- 12,000rpm direct-drive spindle produces an extra 80Nm high torque output.
- 32-tool magazine

12,000 rpm Direct Drive Spindle

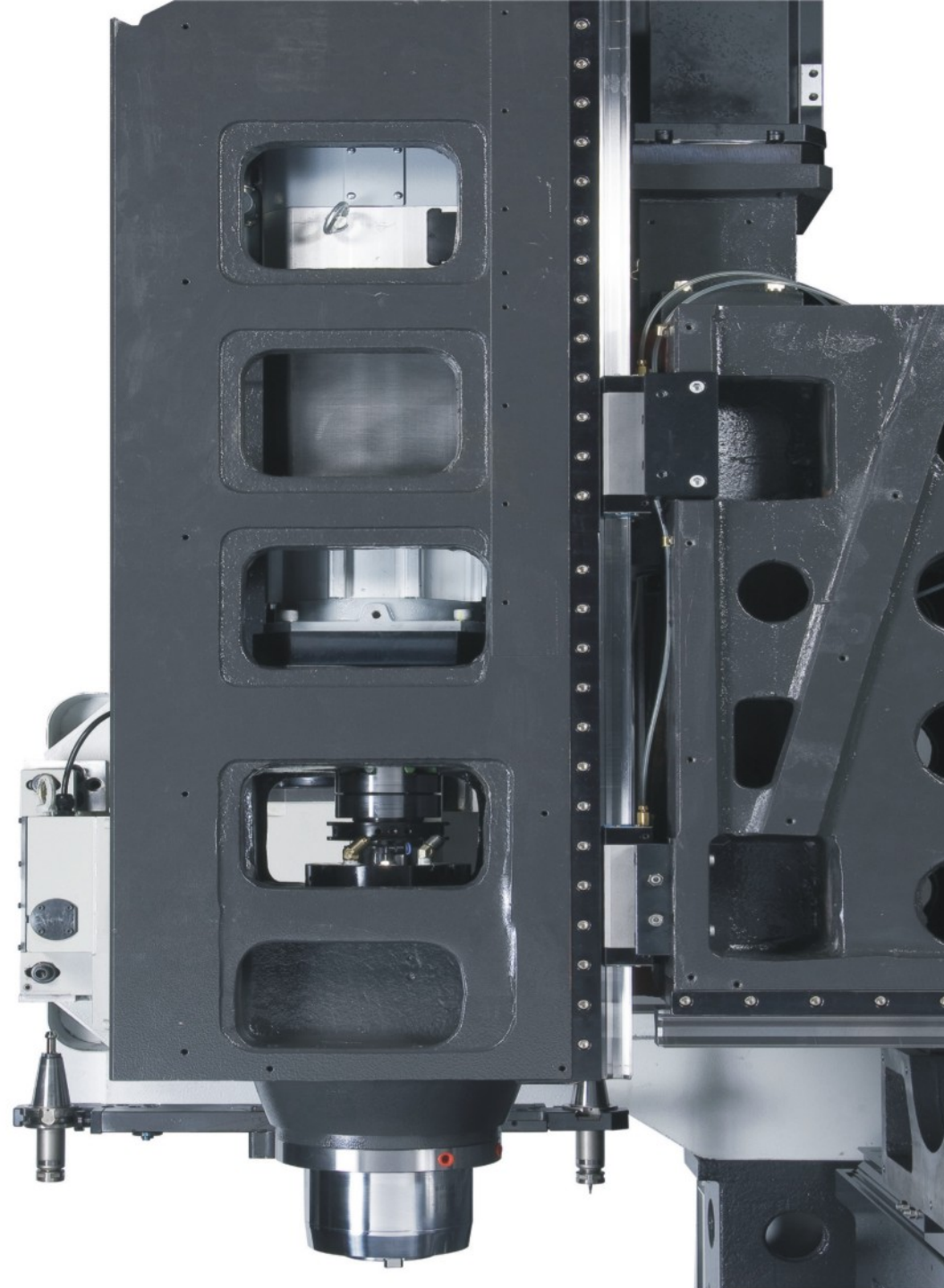
The direct drive spindle eliminates noise, backlash and vibration problems that usually occur on a belt or gear driven spindle.

The direct-drive spindle not only ensures full power transmission efficiency, but also features speed detection for improved rigid tapping quality.

Excellent Thermal Isolation Design

The heat isolated spindle minimizes thermal displacement, resulting in high spindle accuracy and long service life.

The coupling between the motor and the spindle is also heat isolated, combined with the use of an optional oil cooler further minimizes displacement.

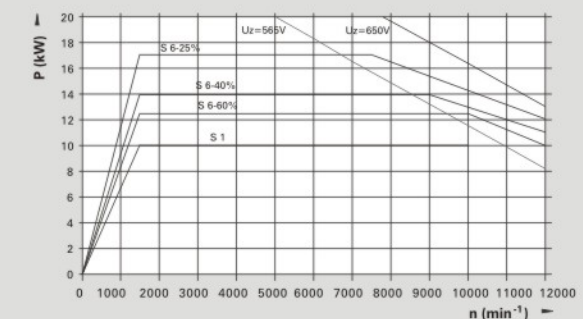


HEIDENHAIN SPINDLE MOTOR

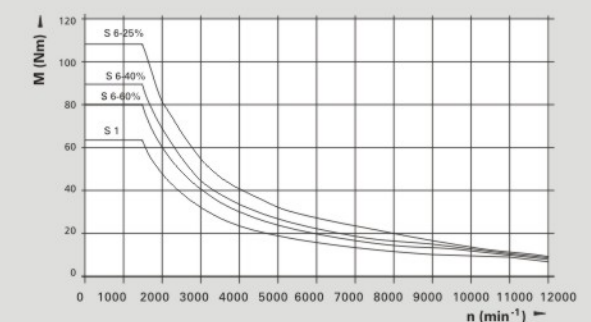
HEIDENHAIN iTNC-530 SPINDLE MOTOR

Duty Cycle	Speed n min ⁻¹	Power P kW	Torque M Nm	Current i
S1	1500	10.0	63.7	25.0A
	11000	10.0	8.7	
	12000	8.0	6.4	
S6-60%	1500	12.5	79.8	29.0A
	11000	12.5	11.9	
	12000	10.0	8.0	
S6-40%	1500	14.0	89.4	32.0A
	9000	14.0	19.1	
	12000	11.0	8.8	
S6-25%	1500	17.0	108.6	37.0A
	7500	17.0	21.7	
	12000	12.0	9.5	

Power characteristic curve



Torque characteristic curve



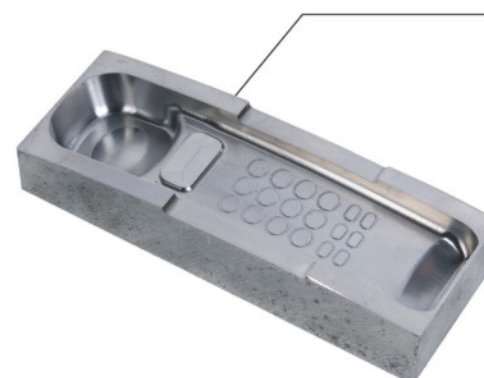
Comparison in Mold Machining 3-axis VMC Vs. 5-axis VMC

3-axis VMC



Machine price	<input type="checkbox"/>	Low
Surface roughness	<input type="checkbox"/>	Good
Tool life	<input type="checkbox"/>	Short
Machining time	<input type="checkbox"/>	Long

5-axis VMC

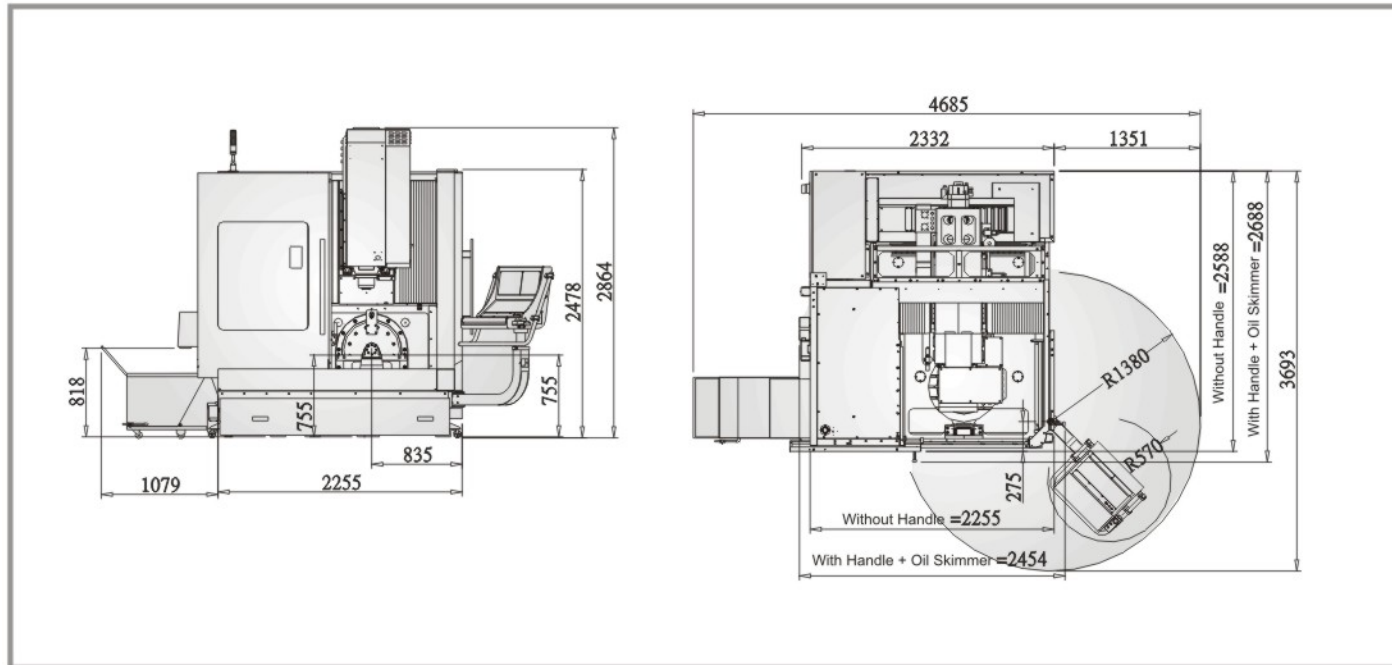


Machine price	<input type="checkbox"/>	High
Surface roughness	<input type="checkbox"/>	Excellent
Tool life	<input type="checkbox"/>	Long
Machining time	<input type="checkbox"/>	Short

Dimension and Working Area

Working Area and Interference Diagram

Dimension



Working Area

Unit:mm

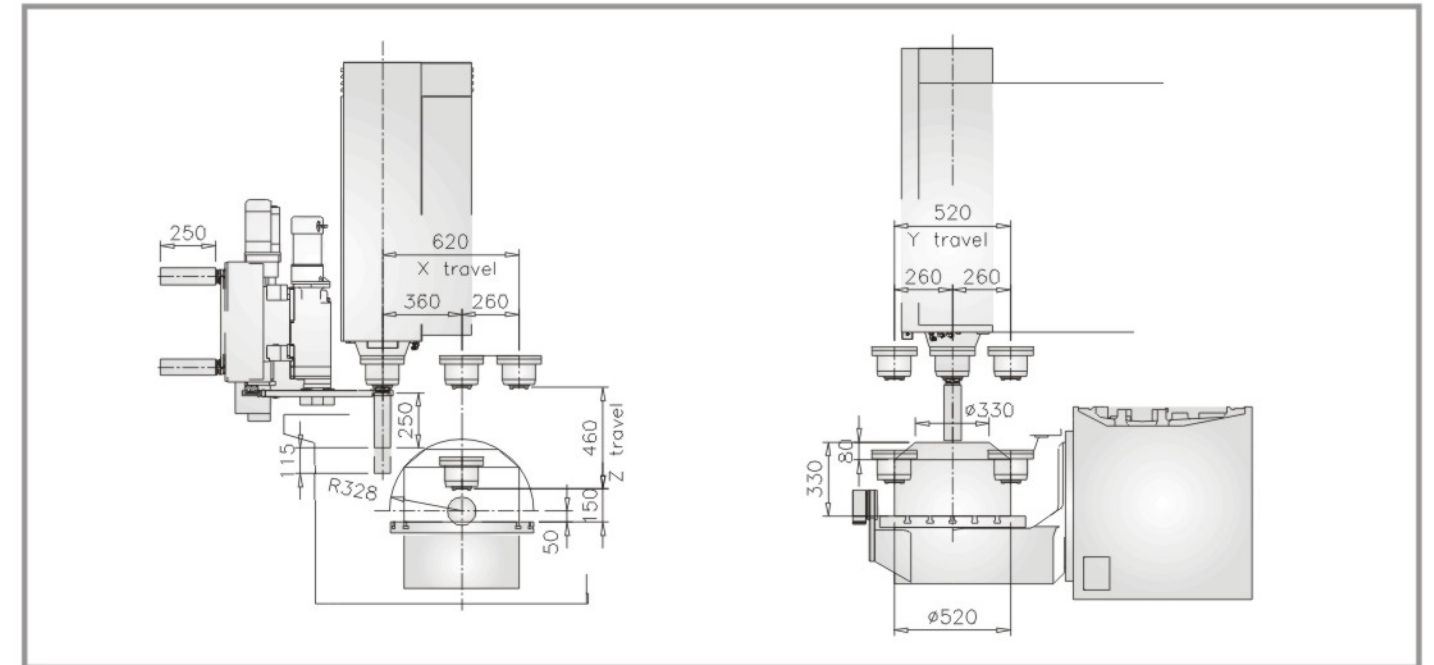
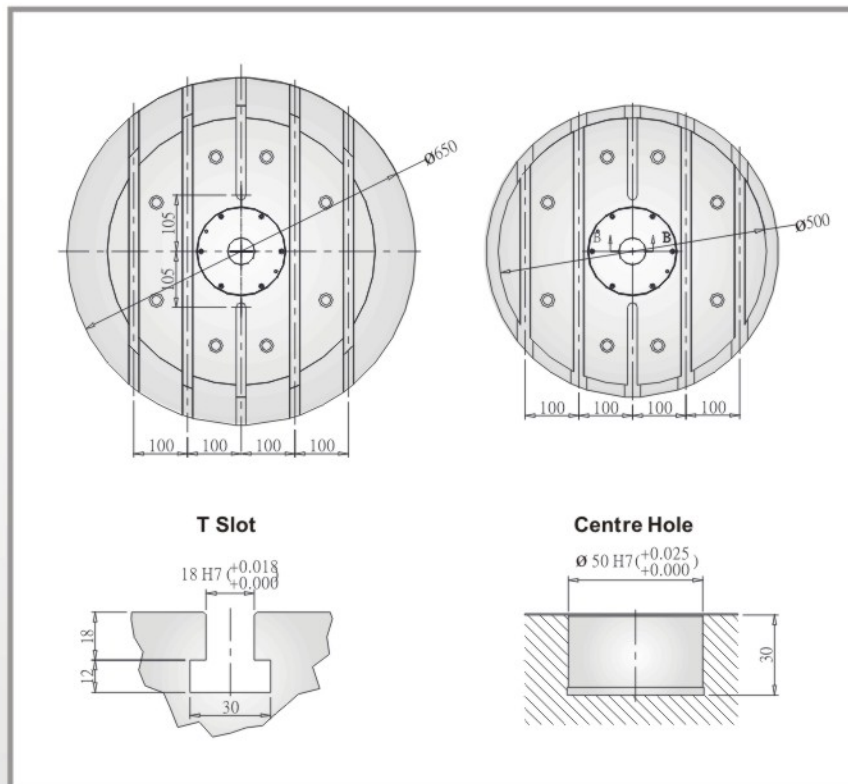
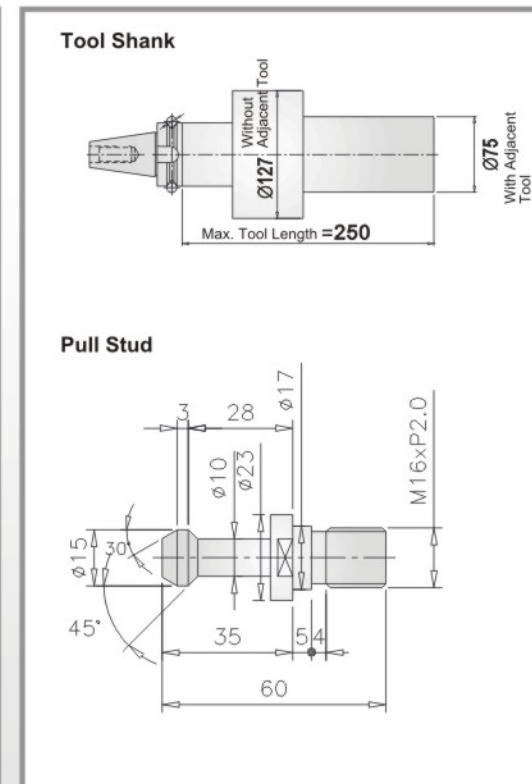


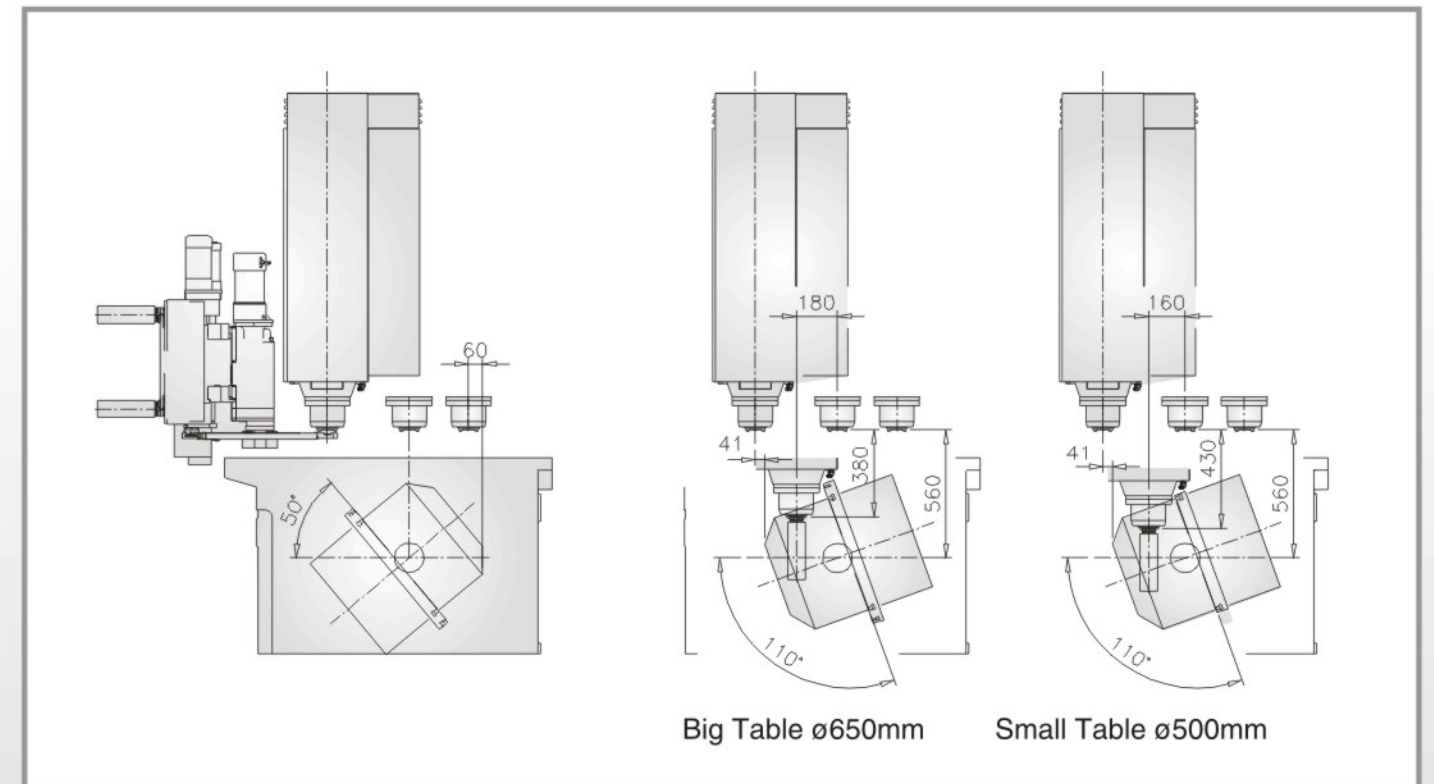
Table size



Tool Shank & Pull Stud



Interference Diagram

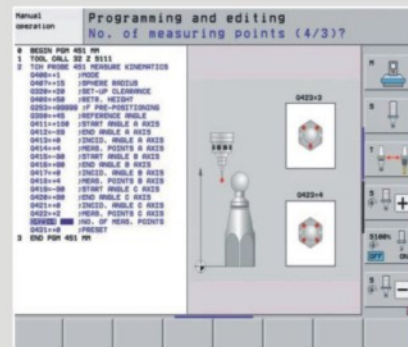


Cutting Test Report

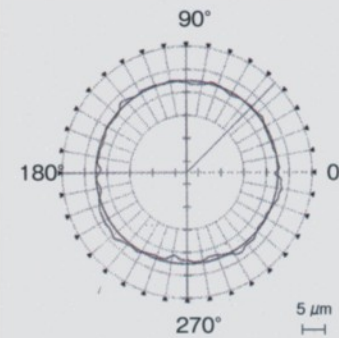


Table Centre Calibrating Device (optional)

The device employs a Heidenhain TS-740 high precision probe, standard measuring ball and measuring software for accurately inspecting the table centre. The measured value is then input into the control system to ensure the accuracy of the table centre.



Circularity (5 axes simultaneously controlled)
(NAS 979 standard)



Circularity (actual cutting values)
→ 0.008 mm

Cutting condition:

Workpiece material (JIS)	A7075 (Aluminum alloy)
Tool	Extra hard end mill ø40 mm (2 flutes)
Spindle speed	2000 rpm
Cutting feed rate	2000 mm/min
Workpiece sizes	ø216mm x ø250mm x H 63.5mm

Machine Specification

Model	ML-620	
Travel		
X/Y/Z Travel	mm	620/520/460
B Axis tilting range		-50° ~ +110°
C Axis rotating range		360°
Spindle nose to table surface	mm	150~610

Spindle		
Spindle transmission		Direct drive
Spindle taper		ISO 40
Spindle rpm	rpm	12000

ATC		
Tool magazine capacity	T	32
Tool shank		NBT 40
Max. tool length	mm	250
Max tool diameter	mm	ø76(ø127)
(without adjacent tool)		

Motor		
Spindle (cont. / 30 min.)	Kw	10/12.5
X/Y/Z axis drive motor	Kw	7.2/5.0/7.2
B, C axis motor	Kw	9.6/5.0

B, C Axis		
Table size (O.D. / I.D.)	mm	ø650/ø500
Centre hole size	mm	ø50H7x30
T-slot number / pitch / size	mm	5x100x18
Max. workpiece size	mm	ø520x330L
Max. table load	kg	300

Rapid Feed		
X/Y/Z axis rapid feedrate	M/min	36/36/36
B/C axis rapid feedrate	rpm	25
Cutting feedrate	mm/min	1-20000

Controller		
Type		HEIDENHAIN iTNC530(5)

Miscellaneous		
Machine weight	kg	8800
Coolant tank capacity	L	240
Dimension	mm	2260x2560x3000
Power consumption	KVA	25
Pneumatic supply	Kg/cm ² (L./min)	6(1600)



Standard Accessories

- Spindle speed 12000 rpm
- Spindle oil chiller
- Spindle air sealing
- Programmable cutting air blast system
- Ring type cutting coolant flush system
- Coolant gun
- Air gun
- Full enclosure splash guard
- Large table size 650 mm.
- Interlock front / side door
- Mechanical oil / coolant separation design
- Auto tool changer
- Tool shank NBT-40
- Tool magazine capacity 32T
- Roller linear guideways
- Z axis motor with brake system
- Work lamp
- Pilot lamp
- M30 power off
- Heat exchanger for electrical cabinet
- Software for crash protection
- CE conformity specification
- Transformer
- 3-axis optical linear scale
- B axis encoder
- C axis encoder

Optional Accessories

- Coolant through spindle
- Stop block for oil holder
- Programmable cutting coolant nozzle
- Coolant cooling system
- Chain type swarf conveyor
- Swarf cart
- Swarf flushing system
- Centreing function
- Laser tool length measurement system TL Micro 200
- Contact type tool length measurement system TT140
- Work piece measurement system TS640
- Tailstock for table
- Air supply for clamping fixture
- Round metal plate type Oil Skimmer
- Tool shank CAT-40
- Air conditioner for electrical cabinet
- FAN C 0iMD (5 controllable axes / 4 simultaneous axes)
- Heidenhain iTNC-530 (5 controllable axes / 5 simultaneous axes)
- Centreing function
- Oil mist collector
- Spinning window
- Spindle motor connecting plate cooling